

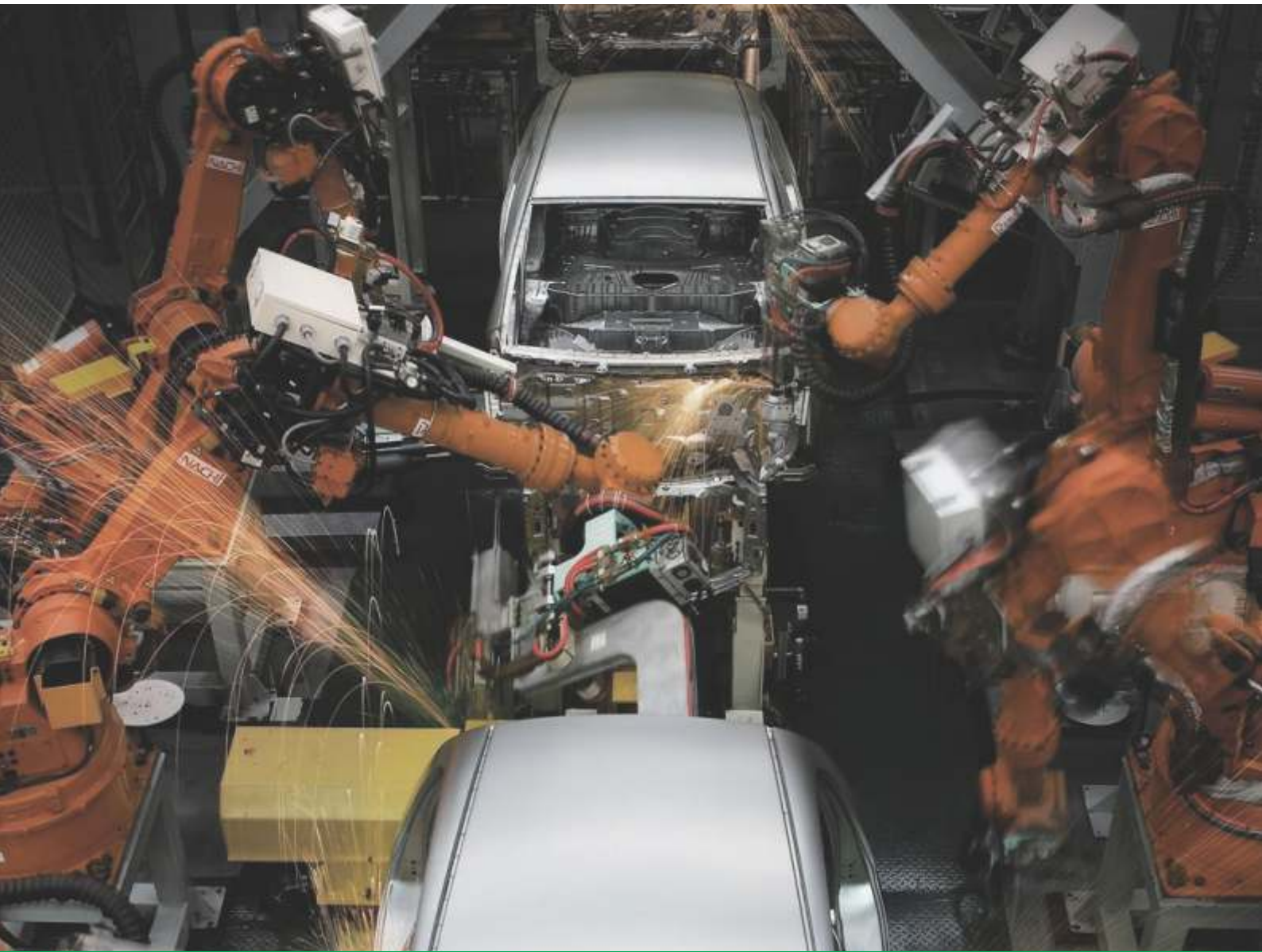

Heavy Duty Shock Absorber





**FOCUSES ON COST-EFFECTIVE ENERGY
ABSORPTION AND VIBRATION ISOLATION
SOLUTIONS.**



Heavy Duty Shock Absorbers



EI Series Heavy Industry Shock Absorbers

Overview	4-5
Technical Data	6-7



ED Series Heavy Duty Shock Absorbers

Overview	8
Technical Data and accessories	9-16

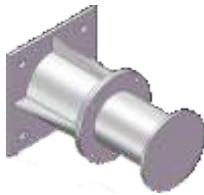

SB Series Spring Buffer

Technical Data	17
----------------------	----



State Of Art Facility in India with
CNC Machines , heat treatment
and Full 100% Dynamic Testing



Adoni tech specializes in research and development, manufacture, testing and solutions of energy absorption and vibration control products like hydraulic shock absorbers, viscous dampers, wire rope vibration isolators, polyurethane cushions etc. R&D and manufacture are based in Satara in Maharashtra India. Currently, ADONI TECH has 4 complete product lines and the leading product testing lab in the industry.

ADONI TECH'S product's differences and features:

- Leading product design in the world.
- All the key components use top brand products in the industry, more than 60% components are originally from India.
- Standardized assembly process.
- High precision, testing of whole series equipments, testing rate of finished products as high as 100%. ADONI TECH'S Brand Advantages:
- Excellent working life and performance.
- Prompt product delivery, enough safety inventories.
- Quick and good technical supports such as product sizing, product testing, and solutions.
- On-site service support from domestic professionals within 24 hours



Overview

very strong energy absorption capacity for single shock, particularly suitable for safety stop of large or super large equipments. Heavy Industry Shock Absorbers are widely used in Cranes, Rail equipments, Steel industry, Coal, Railway and other fields. Large-Bore and High Energy Capacity design ensures reliable energy absorption capacity and long service life.

This type of products is particularly suitable for buffer applications in safety protection. Single product comes with the leading energy absorption capacity in the industry, stable performance during long stand-by time is also ensured.



Features and Benefits

- Compact design, decelerates smoothly and safely, great energy absorption capacity loads up to 4 million in-lbs(500KNm) per cycle with standard stroke lengths.
- Nitrogen-charged return system allows for soft deceleration and positive return in a maintenance-free package.
- Wide variety of optional configurations including protective bellows and safety cables.
- Available in custom-orificed non adjustable models.
- Special epoxy painting and rod materials are available for use in highly corrosive environments.
- Surface treatment(Sea water resistant)
Housing: gray color, three-part epoxy
Piston Rod: hard-chrome plated steel
- Optional galvanized surface finishes for newly upgraded products enhances corrosion resistance performance.
- Incorporating optional fluids and seal packages available to expand standard operating temperature range from (-10°C to 60°C) to (-35°C to 100°C)

Heavy Industry EI Series Shock Absorbers

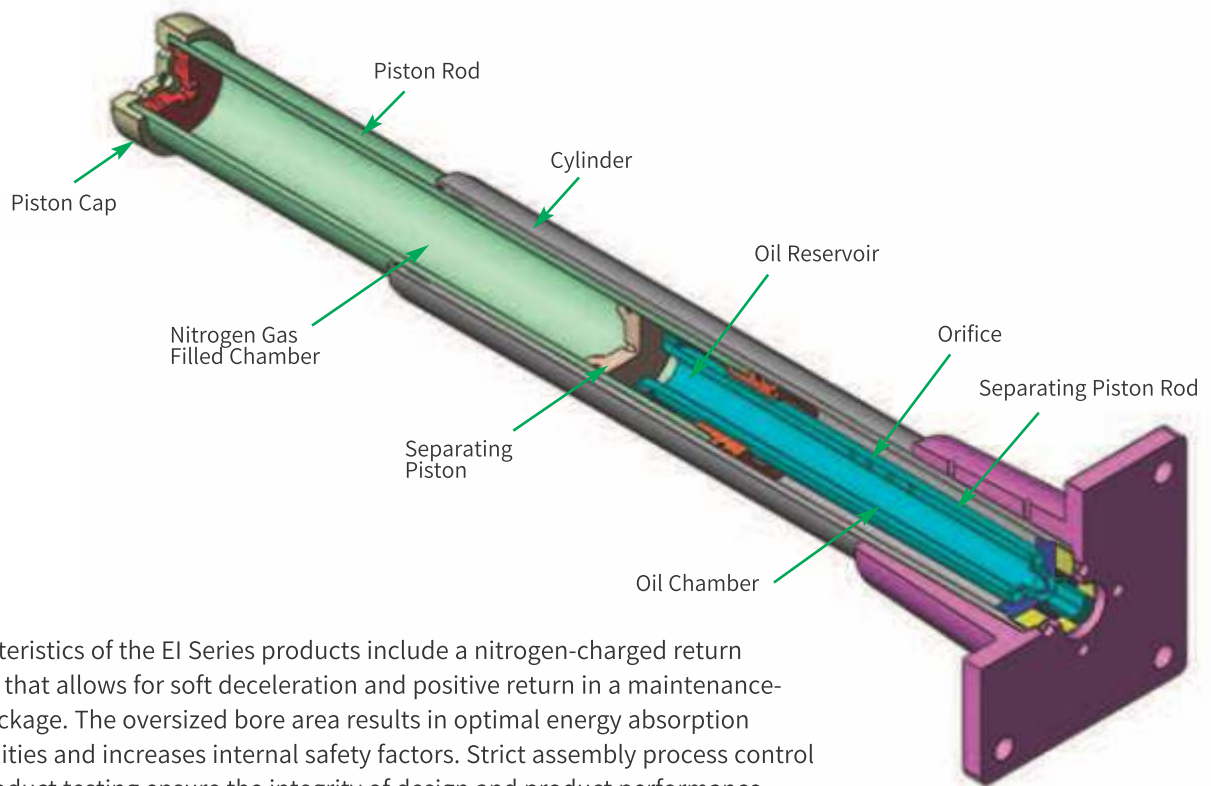

Characteristics of the EI Series products include a nitrogen-charged return system that allows for soft deceleration and positive return in a maintenance-free package. The oversized bore area results in optimal energy absorption capabilities and increases internal safety factors. Strict assembly process control and product testing ensure the integrity of design and product performance.

Prior to EI Series shock absorber manufacture, computer-simulated response curves are generated to model actual conditions, verify product performance, confirm damping characteristics and generate unique custom-orificed design that accommodates multi-condition or specific damping requirements.

Ordering Example

Standard: Rear or Front mount

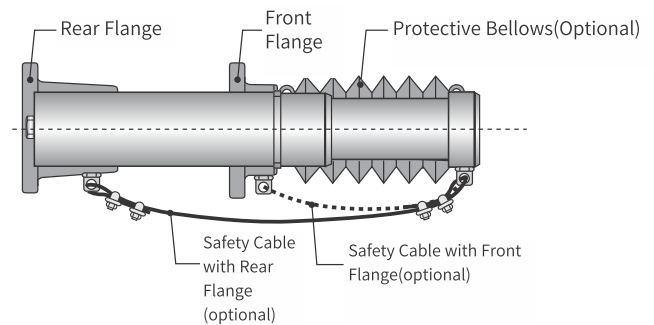

Example:

4
Select quantity

EI 120 x 100
Select EI Series model from Engineering Data Chart

FR
Select mounting method
• FF (Flange Front)
• FR (Flange Rear)

B
Additional Options
• B Protective Bellows
• C Safety Cable

APPLICATION DATA
APPLICATION DATA (Required for all models)

- Vertical / Horizontal Motion
- Weight
- Impact Velocity
- Propelling Force(if any)
- Cycles / Hour
- Temperature / Environment
- Applicable Standards

EI 50 x 50 → EI 120 x 1000 Series

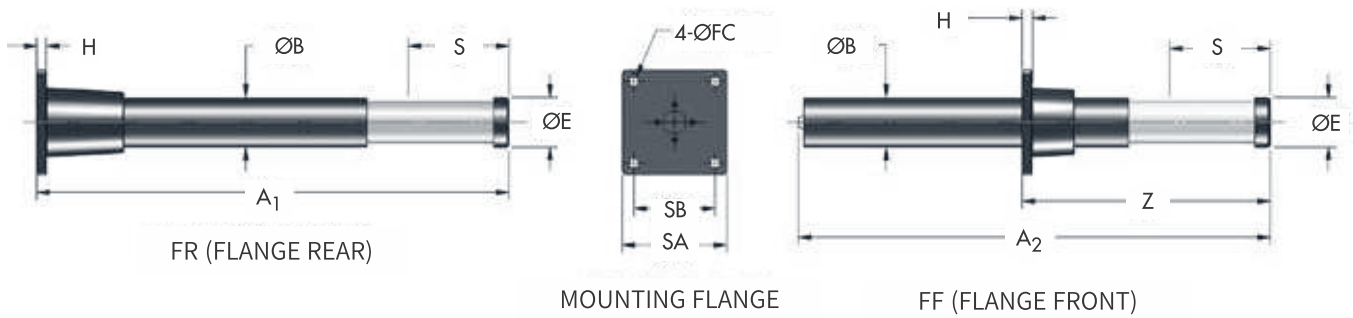

Catalog No. / Model	(S) Stroke mm	Max. Energy / Cycle Nm/C	Max. Shock Force kN	Return Force		Weigh Kg	A ₁ mm	A ₂ mm	Z mm	H mm	ØB mm	SA mm	SB mm	ØFC mm	Bolt Size mm	ØE mm
				Extension kN	Compression kN											
EI 50 x 50	50	3 500	70	0.5	3.2	5	262	—	—	15	65	100	70	14.5	M14	58
EI 50 x 100	100	6 900	70	0.3	0.6	9	392	—	—	15	65	100	70	14.5	M14	58
EI 80 x 50	50	7 800	160	1.0	1.9	16	324	—	—	15	85	128	89	20	M18	79
EI 80 x 100	100	15 600	160	1.0	8.0	22	424	—	—	15	85	128	89	20	M18	79
EI 100 x 50	50	11 500	235	1.65	18.0	16	302	301	175	20	100	150	120	18.5	M16	99
EI 100 x 100	100	23 000	235	1.65	18.0	22	479	473	245	20	100	150	120	18.5	M16	99
EI 100 x 150	150	34 500	235	1.65	18.0	28	618	612	300	20	100	150	120	18.5	M16	99
EI 100 x 200	200	46 000	235	1.65	18.0	32	756	750	390	20	100	150	120	18.5	M16	99
EI 100 x 400	400	92 000	235	1.65	18.0	46	1 349	1 345	645	20	100	150	120	18.5	M16	99
EI 100 x 500	500	108 000	235	1.65	18.0	52	—	1 616	890	20	100	150	120	18.5	M16	99
EI 100 x 600	600	129 000	220	1.65	18.0	58	—	1 888	1 040	20	100	150	120	18.5	M16	99
EI 100 x 800	800	156 000	200	1.65	18.0	69	—	2 426	1 345	20	100	150	120	18.5	M16	99
EI 120 x 100	100	37 000	375	2.8	50.0	34	471	467	270	20	120	220	170	26.5	M24	127
EI 120 x 150	150	55 000	375	2.8	50.0	39	597	593	330	20	120	220	170	26.5	M24	127
EI 120 x 200	200	74 000	375	2.8	50.0	43	724	720	390	20	120	220	170	26.5	M24	127
EI 120 x 300	300	108 000	375	2.8	50.0	53	973	969	520	20	120	220	170	26.5	M24	127
EI 120 x 400	400	144 000	375	2.8	50.0	87	1 225	1 221	680	25	120	220	170	26.5	M24	127
EI 120 x 600	600	216 000	375	2.8	50.0	105	—	1 725	915	25	120	220	170	26.5	M24	127
EI 120 x 800	800	259 000	330	2.8	50.0	110	—	2 332	1 290	25	120	220	170	26.5	M24	127
EI 120 x 1000	1000	299 000	300	2.8	50.0	116	—	2 836	1 360	25	120	220	170	26.5	M24	127

EI 130 x 250 → EI 150 x 1000 Series

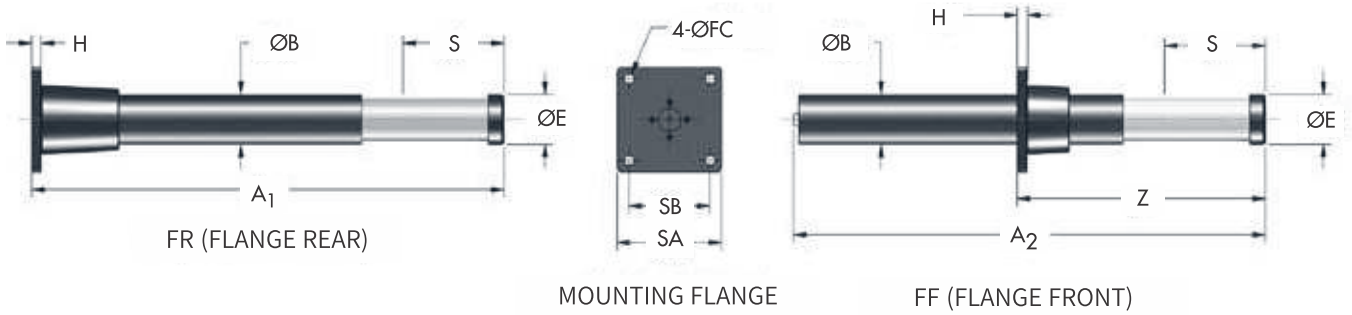

Catalog No. / Model	(S) Stroke mm	Max. Energy/Cycle Nm/C	Max. Shock Force kN	Return Force		Weigh Kg	A ₁ mm	A ₂ mm	Z mm	H mm	ØB mm	SA mm	SB mm	ØFC mm	Bolt Size mm	ØE mm
				Extension kN	Compression kN											
EI 130 x 250	250	115 000	475	3.2	50.0	72	897	894	545	25	130	270	210	26.5	M24	129
EI 130 x 300	300	138 000	475	3.2	50.0	79	1 029	1 025	605	25	130	270	210	26.5	M24	129
EI 130 x 400	400	184 000	475	3.2	50.0	90	1 293	1 289	735	25	130	270	210	26.5	M24	129
EI 130 x 600	600	242 000	400	3.2	45.0	119	—	1 917	1 055	25	130	270	210	26.5	M24	129
EI 130 x 800	800	311 000	400	3.2	45.0	140	—	2 445	1 345	25	130	270	210	26.5	M24	129
EI 150 x 115	115	71 000	645	5.0	65.7	56	516	513	320	25	150	270	210	26.5	M24	149
EI 150 x 150	150	94 000	645	5.0	65.7	59	606	602	355	25	150	270	210	26.5	M24	149
EI 150 x 400	400	253 000	645	5.0	62.4	98	1 257	1 245	710	25	150	270	210	26.5	M24	149
EI 150 x 500	500	316 000	645	5.0	75.5	110	—	1 498	770	25	150	270	210	26.5	M24	149
EI 150 x 600	600	380 000	645	5.0	75.5	120	—	1 752	875	25	150	270	210	26.5	M24	149
EI 150 x 800	800	515 000	640	5.0	68.0	165	—	2 363	1 240	25	150	270	210	26.5	M24	149
EI 150 x 1000	1000	587 000	600	5.0	61.0	180	—	2 880	1 595	25	150	270	210	26.5	M24	149



Heavy Duty Shock Absorber is designed with internal air accumulator with compact structure. This series product provides very smooth damping force with high energy absorption capacity. They are designed for a wide variety of stroke lengths with super long working life, and widely used in Automated storage, Rail Equipments, Trolley Cranes, Automatic Production Lines which have high requirements for deceleration and smooth damping force.

Custom-orificed design accommodates specific damping requirements. Computer generated output performance simulation is used to optimize the orifice configuration. Available in standard bore dimensions of up to 200mm and strokes over 1524mm

Available in the latest model with galvanized surface finishes to enhance corrosion resistant capability.

Features and Benefits ED

- Designed with environmentally friendly materials and fluids
- Compact design, decelerates smoothly and safely, large energy capacity loads up to 3,000,000 in-lbs. per cycle(330 000 Nm)
- Internal charged air/oil accumulator replaces mechanical return springs, providing shorter overall length and reduced weight.
- Optional Bladder Accumulator(BA) for higher cycle rates also available.
- Wide variety of optional configurations including bellows, clevis mounts and safety cable.
- Painted external components provide excellent corrosion protection. Galvanized surface finishes is also available.
- Epoxy painting and special rod materials are available for use in highly corrosive environments.
- All sizes are fully field repairable.
- Piston rod extension sensor systems available for re-use safety requirements.
- Incorporating optional fluids and seal package can expand standard operating temperature range from (-10°C to 60°C) to (-35°C to 100°C)

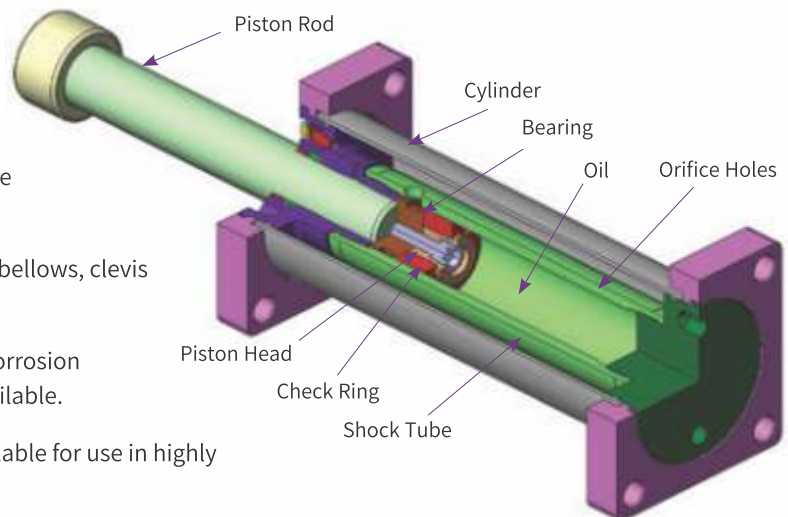

ED 1.5 x 2 → ED 1.5 x 32 Series

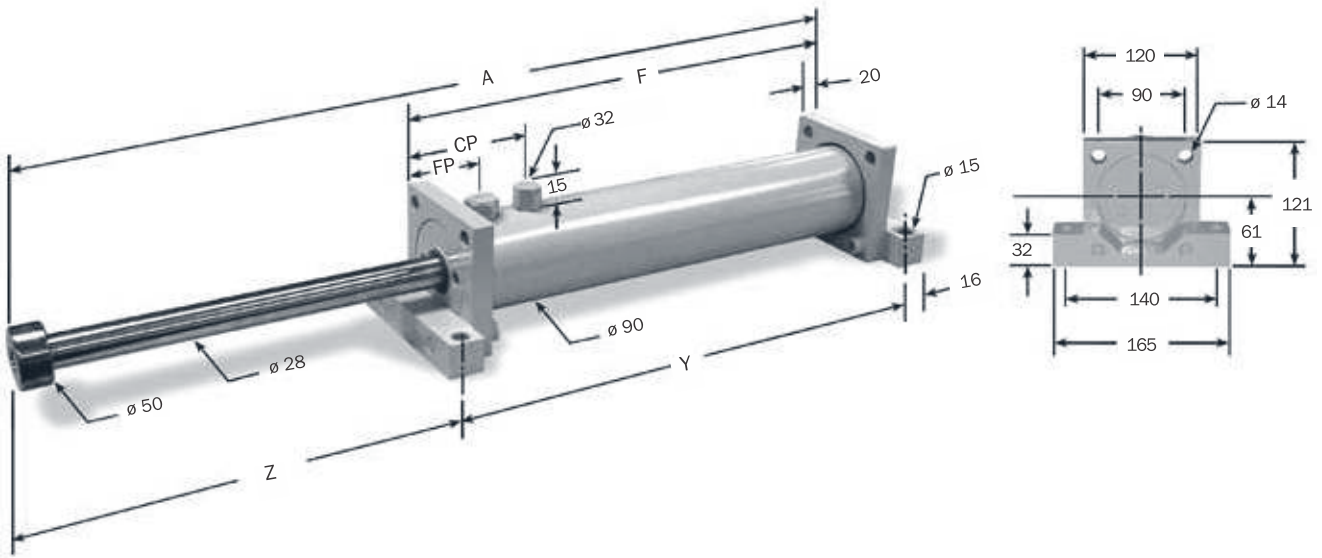

Dimensions are in millimeters

Note: For TF, FF and FR mounting, delete front foot and dimensions

Catalog No./ Model	(S) Stroke mm	(E _T) Max. Energy Nm/C	(E _T C) Max. Energy Nm/h	(F _p) Max. Shock Force N	Nominal Return Force BA* N	Nominal Return Force w/o BA* N	A mm	F mm	Y mm	Z mm	With BA		CP** w/o BA* mm	Weight kg
											CP BA* mm	FP BA* mm		
ED 1.5 x 2	50	3 200	189 000	70 060	220	320	310	208	240	86	139	86	41	10
ED 1.5 x 4	100	6 100	368 000	70 060	220	410	410	258	290	136	139	86	41	12
ED 1.5 x 6	150	9 100	546 700	70 060	220	450	510	308	340	186	139	86	41	12
ED 1.5 x 8	200	12 200	732 500	70 060	220	525	613	360	392	237	139	86	41	13
ED 1.5 x 10	250	15 200	781 000	70 060	220	600	715	411	443	288	139	86	41	14
ED 1.5 x 12	300	18 300	877 900	70 060	220	920	817	462	494	339	139	86	41	16
ED 1.5 x 14	350	20 900	972 900	70 060	220	1 120	918	512	544	390	139	86	41	17
ED 1.5 x 16	400	23 300	1 069 800	60 060	220	1 120	1 019	563	595	440	139	86	41	18
ED 1.5 x 18	450	25 300	1 166 700	47 820	220	1 120	1 121	614	646	491	139	86	41	19
ED 1.5 x 20	500	27 200	1 263 600	38 920	220	1 120	1 223	665	697	542	139	86	41	20
ED 1.5 x 24	600	30 500	1 457 400	27 800	220	1 120	1 427	767	799	644	139	86	41	23
ED 1.5 x 28	713	33 600	1 649 300	21 130	220	1 120	1 629	868	900	745	139	86	41	20
ED 1.5 x 32	813	36 500	1 839 300	16 460	220	1 120	1 830	968	1 000	846	139	86	41	23

Notes:

- ED shock absorbers will function satisfactorily at 5% of their maximum rated energy per cycle. If less than these values, a smaller model should be specified.
- It is recommended that the customer consult company for safety-related overhead crane applications.
- The energy data listed is for ideal linear impacts only. If side load conditions exist in the application, contact company for sizing assistance.
- Rear flange mounting of 300 mm strokes and longer not recommended. Front and rear flange or foot mount configurations are recommended.
- Maximum cycle rate is 60 cycles/hr. for ED with BA (Bladder Accumulator) option and 30 cycles/hr. without BA option.
- For impact velocities over 4.5m/s, consult factory.

ED 2.0 x 6 ➔ ED 2.0 x 56 Series

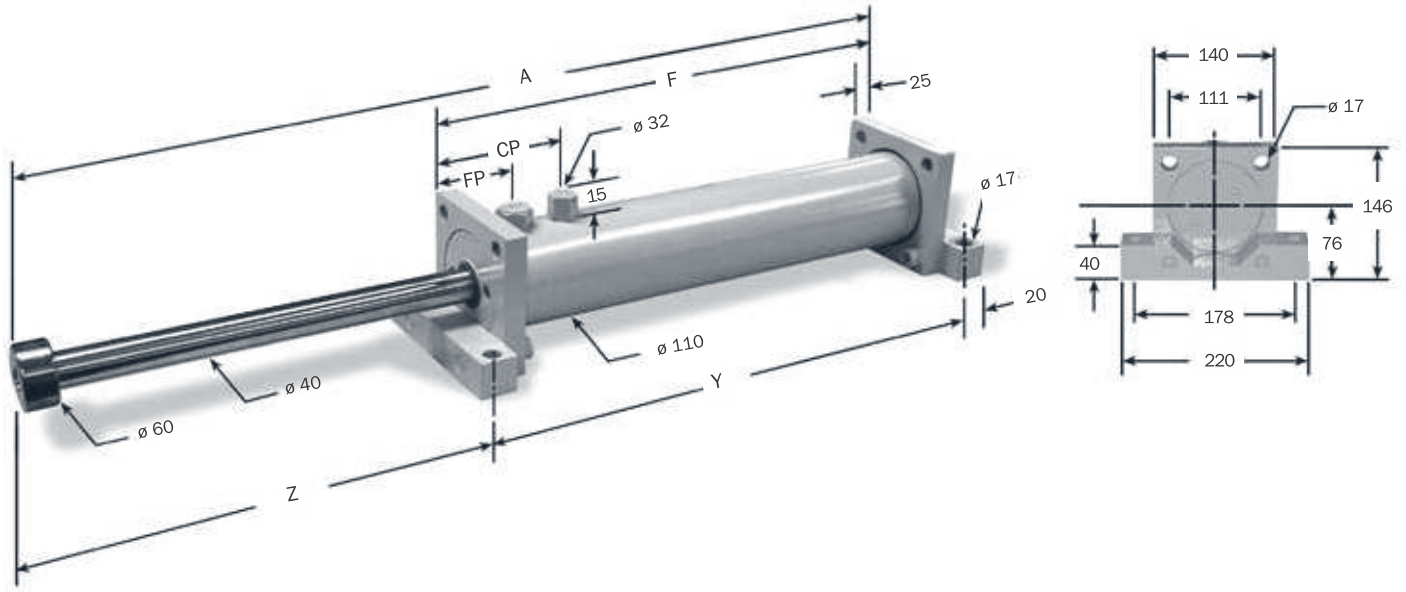

Note: For TF, FF and FR mounting, delete front foot and dimensions

Dimensions are in millimeters

Catalog No./ Model	(S) Stroke mm	(E _T) Max. Energy Nm/C	(E _T C) Max. Energy Nm/h	(F _P) Max. Shock Force N	Nominal Return Force BA*	Nominal Return Force w/o BA*	A mm	F mm	Y mm	Z mm	With BA		CP** w/o BA* mm	Weight kg
											CP BA* mm	FP BA* mm		
ED 2.0 x 6	152	17 200	862 100	111 200	535	870	553	339	379	194	176	96	46	23
ED 2.0 x 8	203	23 000	913 700	111 200	535	1 040	655	390	430	245	176	96	46	25
ED 2.0 x 10	250	28 800	1 033 200	111 200	535	1 340	757	441	481	296	176	96	46	23
ED 2.0 x 12	300	34 300	1 152 700	111 200	535	2 290	859	492	532	347	176	96	46	25
ED 2.0 x 14	350	38 700	1 272 100	111 200	535	2 290	960	543	583	397	176	96	46	27
ED 2.0 x 16	400	43 200	1 391 600	111 200	535	2 290	1 062	594	634	448	176	96	46	29
ED 2.0 x 18	450	47 600	1 511 100	111 200	535	2 290	1 164	645	685	499	176	96	46	31
ED 2.0 x 20	500	51 900	1 628 300	111 200	535	2 290	1 265	695	735	550	176	96	46	33
ED 2.0 x 24	600	60 800	1 867 200	111 200	535	2 290	1 469	797	837	652	176	96	46	36
ED 2.0 x 28	700	69 800	2 106 200	111 200	535	2 290	1 672	899	939	753	176	96	46	42
ED 2.0 x 32	800	70 700	2 527 900	111 200	535	2 290	1 953	1 079	1 119	854	256	176	46	49
ED 2.0 x 36	900	101 200	2 762 200	100 000	535	2 290	2 151	1 179	1 219	952	256	176	46	53
ED 2.0 x 40	1 000	101 400	2 996 500	84 500	535	2 290	2 351	1 279	1 319	1 052	256	176	46	56
ED 2.0 x 48	1 200	114 500	3 465 000	60 000	535	2 290	2 751	1 479	1 519	1 252	256	176	46	64
ED 2.0 x 56	1 400	125 000	3 957 000	35 100	535	2 290	3 171	1 689	1 729	1 462	256/975	176	46	73

Notes:

- ED shock absorbers will function satisfactorily at 5% of their maximum rated energy per cycle. If less than these values, a smaller model should be specified.
- It is recommended that the customer consult company for safety-related overhead crane applications.
- The energy data listed is for ideal linear impacts only. If side load conditions exist in the application, contact company for sizing assistance.
- Rear flange mounting of 300 mm strokes and longer not recommended. Front and rear flange or foot mount configurations are recommended.
- Maximum cycle rate is 60 cycles/hr. for ED with BA (Bladder Accumulator) option and 30 cycles/hr. without BA option.
- For impact velocities over 4.5m/s, consult factory.
- ED2.0 x 56 has two charge ports.

ED 3.0 x 2 → ED 3.0 x 72 Series

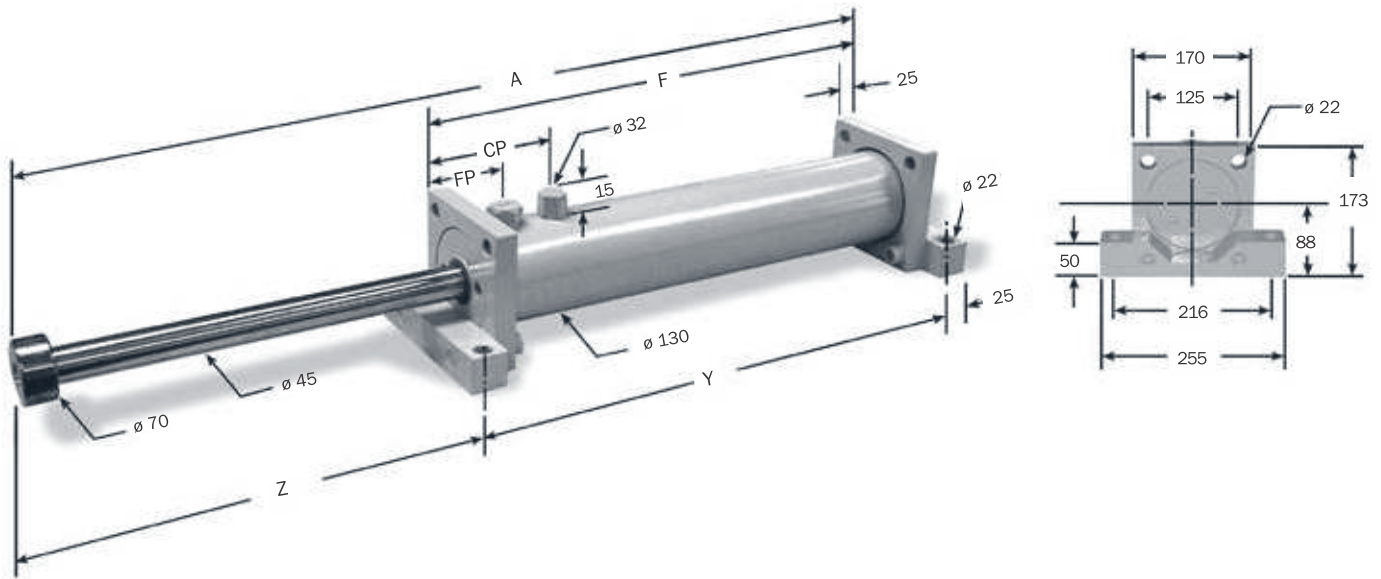

Note: For TF, FF and FR mounting, delete front foot and dimensions

Dimensions are in millimeters

Catalog No./ Model	(S) Stroke mm	(E _T) Max. Energy Nm/C	(E _T C) Max. Energy Nm/h	(F _P) Max. Shock Force N	Nominal Return Force BA* N	Nominal Return Force w/o BA* N	A mm	F mm	Y mm	Z mm	With BA		CP** w/o BA* mm	Weight kg
											CP BA* mm	FP BA* mm		
ED 3.0 x 2	50	9 600	578 500	222 400	670	1 130	336	203	253	108	128	61	46	21
ED 3.0 x 3	75	14 600	659 000	222 400	710	1 810	387	229	279	133	128	61	46	22
ED 3.0 x 5	125	24 200	805 700	222 400	735	2 895	489	280	330	184	128	61	46	25
ED 3.0 x 8	200	35 700	1 021 500	222 400	755	2 895	640	355	405	260	128	61	46	29
ED 3.0 x 10	250	43 200	1 168 300	222 400	780	2 895	742	406	456	311	128	61	46	32
ED 3.0 x 12	300	50 700	1 315 000	222 400	780	2 895	844	457	507	362	128	61	46	35
ED 3.0 x 14	350	62 900	1 605 700	222 400	800	2 895	995	558	608	412	178	111	46	43
ED 3.0 x 16	400	70 400	1 752 400	222 400	800	2 895	1 097	609	659	463	178	111	46	45
ED 3.0 x 18	450	77 900	1 899 200	222 400	800	2 895	1 199	660	710	514	178	111	46	48
ED 3.0 x 20	500	85 400	2 046 000	222 400	800	2 895	1 301	711	761	565	178	111	46	51
ED 3.0 x 24	600	100 300	2 336 600	222 400	800	2 895	1 504	812	862	667	178	111	46	57
ED 3.0 x 28	700	115 300	2 630 100	222 400	800	2 895	1 707	914	964	768	178	111	46	62
ED 3.0 x 32	800	130 200	2 920 700	180 200	800	2 895	1 910	1 015	1 065	870	178	161	46	68
ED 3.0 x 36	900	147 700	3 349 500	160 100	800	2 895	2 156	1 164	1 214	967	228	161	46	77
ED 3.0 x 40	1 000	159 600	3 637 200	140 000	800	2 895	2 356	1 264	1 314	1 067	228	161	46	85
ED 3.0 x 48	1 200	179 700	4 212 800	95 600	825	2 895	2 756	1 464	1 514	1 267	228	161	46	94
ED 3.0 x 56	1 400	196 700	4 788 300	55 600	825	2 895	3 156	1 664	1 714	1 467	228/947	161	46	106
ED 3.0 x 60	1 500	206 800	5 116 300	53 200	825	2 895	3 384	1 778	1 828	1 581	228/1004	161	46	106
ED 3.0 x 64	1 629	217 100	5 210 400	53 200	825	2 895	3 688	1 980	2 030	1 683	439/1 527	260	46	110
ED 3.0 x 72	1 830	238 000	6 242 000	53 200	825	2 895	4 012	2 092	2 142	1 895	439/1 727	260	46	118

Notes:

- ED shock absorbers will function satisfactorily at 5% of their maximum rated energy per cycle. If less than these values, a smaller model should be specified.
- It is recommended that the customer consult company for safety-related overhead crane applications.
- The energy data listed is for ideal linear impacts only. If side load conditions exist in the application, contact company for sizing assistance.
- Rear flange mounting of 300 mm strokes and longer not recommended. Front and rear flange or foot mount configurations are recommended.
- Maximum cycle rate is 60 cycles/hr. for ED with BA (Bladder Accumulator) option and 30 cycles/hr. without BA option.
- For impact velocities over 4.5m/s, consult factory.
- ED3.0 x 72 has two charge ports.



ED 3.5 x 2 → ED 3.5 x 56 Series

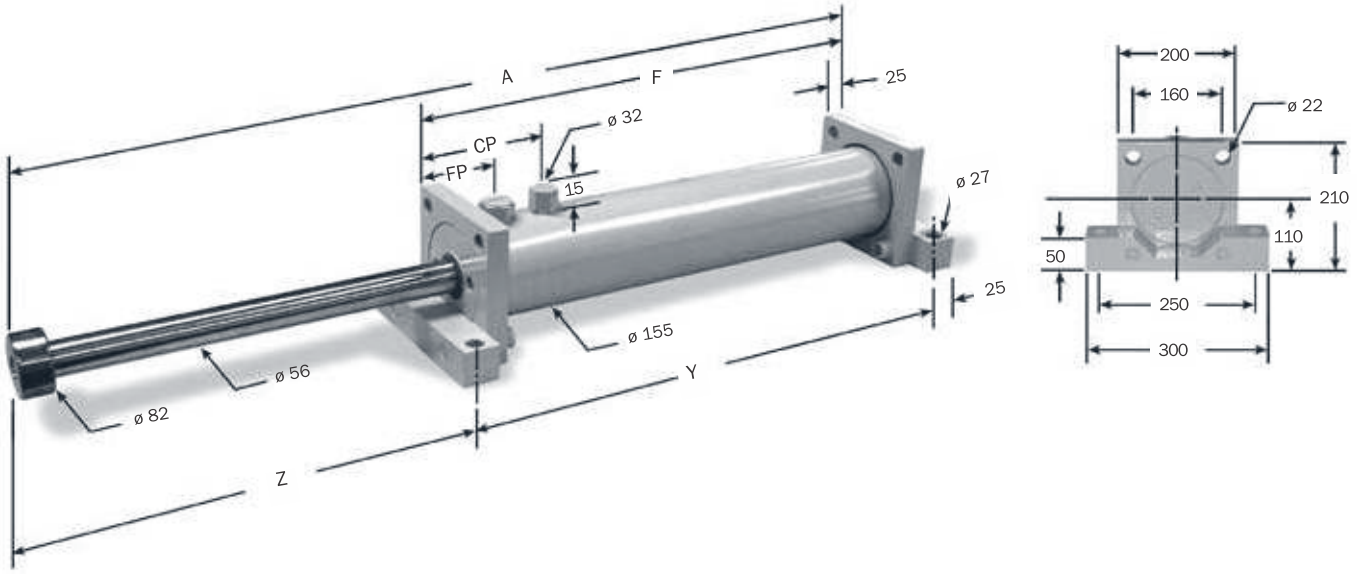

Note: For TF, FF and FR mounting, delete front foot and dimensions

Dimensions are in millimeters

Catalog No./ Model	(S) Stroke mm	(E _T) Max. Energy Nm/C	(E _T -C) Max. Energy Nm/h	(F _P) Max. Shock Force N	Nominal Return Force BA* N	Nominal Return Force w/o BA* N	A mm	F mm	Y mm	Z mm	With BA		CP** w/o BA* mm	Weight kg
											CP BA* mm	FP BA* mm		
ED 3.5 x 2	50	13 000	781 000	300 250	960	2 020	354	244	294	85	134	77	52	33
ED 3.5 x 4	100	26 000	993 500	300 250	1 020	2 710	456	295	345	136	134	77	52	37
ED 3.5 x 6	150	38 800	1 161 900	300 250	1 160	4 480	556	345	395	186	134	77	52	41
ED 3.5 x 8	200	50 900	1 333 600	300 250	1 180	4 480	658	396	446	237	134	77	52	45
ED 3.5 x 10	250	60 800	1 505 400	300 250	1 200	4 480	760	447	497	288	134	77	52	49
ED 3.5 x 12	300	70 800	1 677 200	300 250	1 200	4 480	862	498	548	339	134	77	52	53
ED 3.5 x 16	400	90 500	2 017 300	300 250	1 225	4 480	1 064	599	649	440	134	77	52	60
ED 3.5 x 20	500	118 800	2 546 100	300 250	1 225	4 480	1 323	756	806	542	189	132	52	74
ED 3.5 x 24	600	138 700	2 889 600	300 250	1 250	4 480	1 527	858	908	644	189	132	52	81
ED 3.5 x 28	700	158 500	3 229 700	300 250	1 250	4 480	1 729	959	1 009	745	189	132	52	89
ED 3.5 x 32	800	178 400	3 573 200	300 250	1 250	4 480	1 933	1 061	1 111	847	189	132	52	97
ED 3.5 x 36	900	198 300	3 916 800	260 200	1 250	4 480	2 137	1 163	1 213	949	189	132	52	105
ED 3.5 x 40	1 000	216 800	4 256 900	215 700	1 250	4 480	2 339	1 264	1 314	1 050	189	132	52	112
ED 3.5 x 48	1 200	247 200	4 930 500	155 700	1 250	4 480	2 739	1 464	1 514	1 250	189	132	52	128
ED 3.5 x 56	1 400	273 300	5 604 000	112 500	2 100	4 480	2 739	1 464	1 514	1 250	189/908	132	52	128

Notes:

- ED shock absorbers will function satisfactorily at 5% of their maximum rated energy per cycle. If less than these values, a smaller model should be specified.
- It is recommended that the customer consult company for safety-related overhead crane applications.
- The energy data listed is for ideal linear impacts only. If side load conditions exist in the application, contact company for sizing assistance.
- Rear flange mounting of 300 mm strokes and longer not recommended. Front and rear flange or foot mount configurations are recommended.
- Maximum cycle rate is 60 cycles/hr. for ED with BA(Bladder Accumulator) option and 30 cycles/hr. without BA option.
- For impact velocities over 4.5m/s,consult factory.
- ED3.5 x 56 has two charge ports.

ED 4.0 x 2 → ED 4.0 x 48 Series

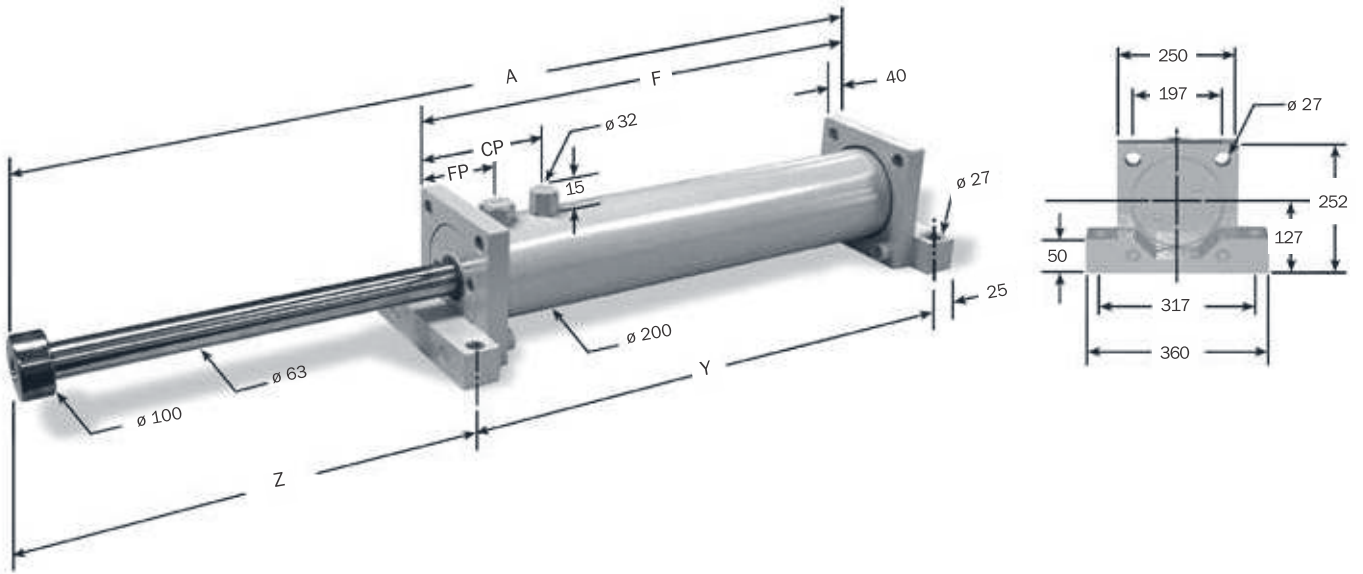

Note: For TF, FF and FR mounting, delete front foot and dimensions

Dimensions are in millimeters

Catalog No./ Model	(S) Stroke mm	(E _T) Max. Energy Nm/C	(E _T -C) Max. Energy Nm/h	(F _P) Max. Shock Force N	Nominal Return Force BA* N	Nominal Return Force w/o BA* N	A mm	F mm	Y mm	Z mm	With BA		CP** w/o BA* mm	Weight kg
											CP BA* mm	FP BA* mm		
ED 4.0 x 2	50	15 700	943 700	355 900	1 100	1 900	430	294	344	111	206	108	64	64
ED 4.0 x 4	100	31 200	1 534 300	355 900	1 200	2 160	532	345	395	162	206	108	64	70
ED 4.0 x 6	150	46 279	1 756 700	355 900	1 200	3 050	632	395	445	212	206	108	64	76
ED 4.0 x 8	200	62 000	1 987 900	355 900	1 200	4 370	735	447	497	263	206	108	64	82
ED 4.0 x 10	250	77,100	2 210 300	355 900	1 200	5 465	836	497	547	314	206	108	64	87
ED 4.0 x 12	300	92 600	1 855 100	355 900	1 225	4 440	1 032	642	692	365	300	202	64	108
ED 4.0 x 16	400	123,100	3 304 300	355 900	1 225	5 650	1 234	743	793	466	300	202	64	120
ED 4.0 x 20	500	154 000	3 757 900	355 900	1 245	5 145	1 438	845	895	568	300	202	64	131
ED 4.0 x 24	600	184 800	4 211 500	355 900	1 245	5 675	1 642	947	997	670	300	202	64	144
ED 4.0 x 28	700	215 100	4 660 700	355 900	1 245	5 675	1 844	1 048	1 098	771	300	202	64	157
ED 4.0 x 32	800	240 500	5 114 300	355 900	1 245	5 675	2 048	1 150	1 200	873	300	202	64	170
ED 4.0 x 36	900	265 900	5 567 900	355 900	1 245	5 675	2 252	1 252	1 302	975	300	202	64	183
ED 4.0 x 40	1 000	289 900	6 017 100	355 900	1 245	5 675	2 454	1 353	1 403	1 076	300	202	64	195
ED 4.0 x 48	1 200	329 300	6 919 900	200 000	1 245	5 675	2 854	1 556	1 606	1 273	300	202	64	220

Notes:

- ED shock absorbers will function satisfactorily at 5% of their maximum rated energy per cycle. If less than these values, a smaller model should be specified.
- It is recommended that the customer consult company for safety-related overhead crane applications.
- The energy data listed is for ideal linear impacts only. If side load conditions exist in the application, contact company for sizing assistance.
- Rear flange mounting of 12 inch(300 mm) strokes and longer not recommended. Front and rear flange or foot mount configurations are recommended.
- Maximum cycle rate is 60 cycles/hr. for ED with BA(Bladder Accumulator) option and 30 cycles/hr. without BA option.
- For impact velocities over 4.5m/s,consult factory.



Typical mounting methods are shown below. Special mounting requirements can be accommodated upon request.



TM: Rear Flange Front Foot Mount



FM: Front and Rear Foot Mount. Also shown is optional safety cable, typically used in overhead applications.



TF: Front and Rear Flanges



FF: Front Flange



CM: Clevis Mount



FR: Rear Flange

Note: Rear flange mounting not recommended for stroke lengths above 12 inches.(300mm)

ED

ED 3.0 x 2 → ED 4.0 x 10 Series

Clevis Mounts (CM)

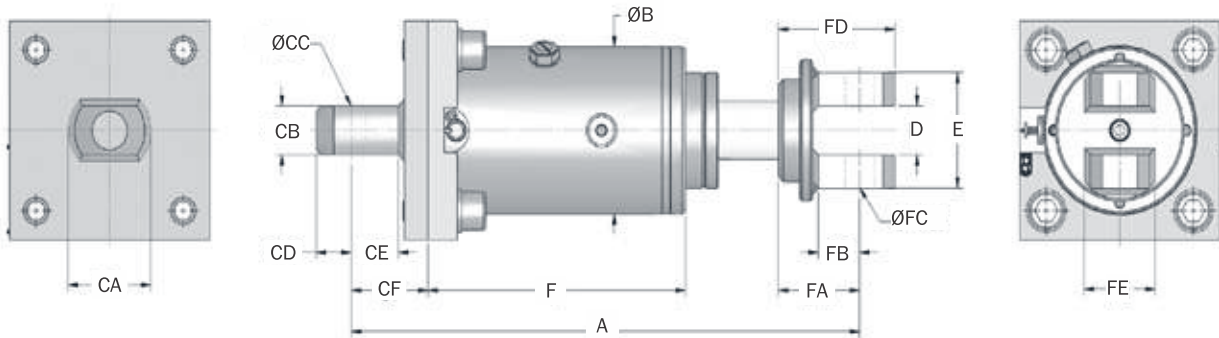

Dimensions are in millimeters

Note: Piston clevis dimensions are typical both ends on ED4.0 models.

Catalog No./ Model	A mm	B mm	D mm	E mm	HD/ED F mm	HDA F mm	Cylinder Clevis Dimensions						Piston Clevis Dimensions				
							CA mm	CB mm	CC mm	CD mm	CE mm	CF mm	FA mm	FB mm	FC mm	FD mm	FE mm
ED 3.0 x 2	432	130	38	90	202	235	60	38	25	30	37	65	69	32	25	99	50
ED 3.0 x 3	483	130	38	90	229	261	60	38	25	30	37	65	69	32	25	99	50
ED 3.0 x 5	585	130	38	90	280	312	60	38	25	30	37	65	69	32	25	99	50
ED 3.0 x 8	736	130	38	90	355	387	60	38	25	30	37	65	69	32	25	99	50
ED 3.0 x 10	838	130	38	90	406	438	60	38	25	30	37	65	69	32	25	99	50
ED 3.0 x 12	940	130	38	90	457	489	60	38	25	30	37	65	69	32	25	99	50
ED 4.0 x 2	570	200	65	140	294	304						90	100	60	50	150	100
ED 4.0 x 4	672	200	65	140	345	355						90	100	60	50	150	100
ED 4.0 x 6	772	200	65	140	395	405						90	100	60	50	150	100
ED 4.0 x 8	875	200	65	140	477	457						90	100	60	50	150	100
ED 4.0 x 10	976	200	65	140	497	507						90	100	60	50	150	100

Optional Piston Rod Return Sensor

- Magnetic proximity sensor indicates complete piston rod return with 10-foot(3m) long cable.
- If complete piston rod does not return the circuit remains open. This can be used to trigger a system shut-off.
- Contact company for other sensor types.
- Sensor port in line with charge port on models ED 1.5,2.0 and 4.0. Location offset 90°for models ED3.0 and 3.5.

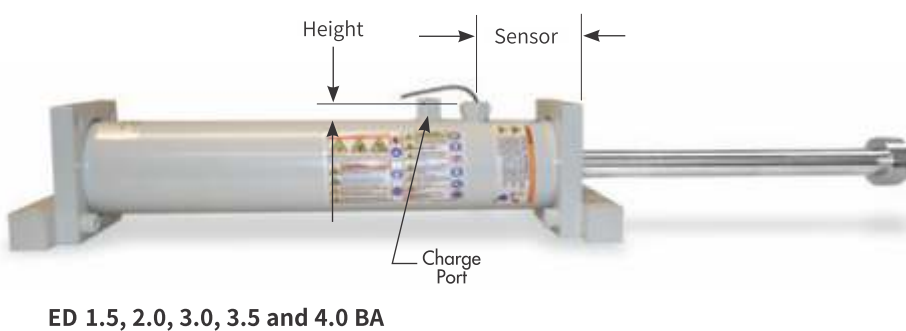
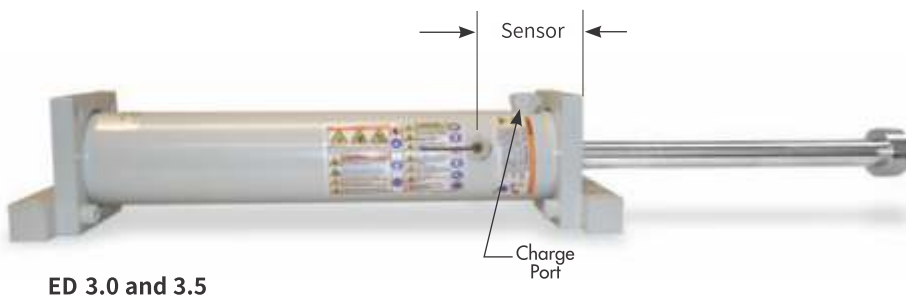
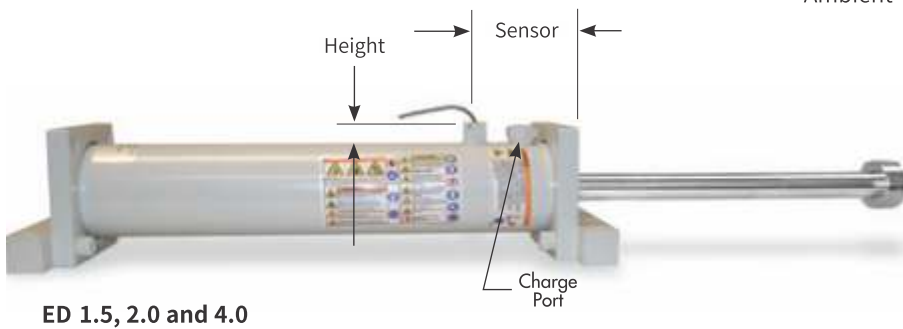

Urethane Cap

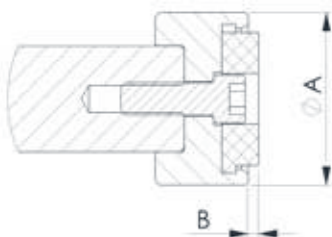

Catalog No./Model	Diameter A mm	B mm
ED 1.5	60	4
ED 2.0	65	4
ED 3.0	70	4

Sensor Specifications

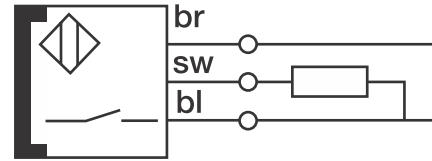

- Voltage 10-30V
- Load Current ≤ 200 mA
- Leakage Current ≤ 80 mA
- Load Capacitance ≤ 1.0 mF
- Ambient Temperature: $-26^{\circ} \sim 71^{\circ}C$

Catalog No./Model	Sensor mm	Height mm
ED 1.5	86	20
ED 2.0 x 6-28	96	16
ED 2.0 x 32-56	176	16
ED 4.0 x 2-10	108	9
ED 4.0 x 12-48	202	9

Catalog No./Model	Sensor mm	Height mm
ED 3.0 x 2-12	61	15
ED 3.0 x 14-32	111	15
ED 3.0 x 36-60	161	15
ED 3.5 x 2-16	77.4	9
ED 3.5 x 20-56	132.4	9

Catalog No./Model	Sensor mm	Height mm
ED 1.5	86	20
ED 2.0 x 6-28	96	16
ED 2.0 x 32-56	176	16
ED 3.0 x 2-12	61	15
ED 3.0 x 14-32	111	15
ED 3.0 x 36-60	161	15
ED 3.5 x 2-16	77.4	9
ED 3.5 x 20-56	132.4	9
ED 4.0 x 2-10	108	9
ED 4.0 x 12-48	202	9

Note: ED models are custom-orificed, therefore all information must be provided to company for unique part number assignment.



Ordering Code Example for Heavy Duty Shock Absorbers

ED

1 - Quantity	4 - Mounting Method	APPLICATION DATA (Required for EI/ED Models)
2 - Model Selection	TM (Rear flange front foot mount)	Vertical or horizontal motion
ED (Non-adjustable)	FM (Front and rear foot mount)	Weight
	TF (Front and rear flanges)	Impact velocity
	FF (Front flange)	Propelling force (if any)
	FR (Rear flange)	Cycles / Hr
	CM (Metric clevis mount)	Other (temperature or other environmental conditions, safety standards, etc)
3 - Model Size	5 - Options	
Select Size from Engineering Data Chart	C (Sensor Cable)	
ED-1.5, 2.0, 3.0,3.5,4.0 Bore Sizes (pages9-13)	B (Dust Guard)	
	SC (Safety Cable)	
	BA (Bladder Accumulator)	
	UC (Urethane Cap)	

Spring Buffer

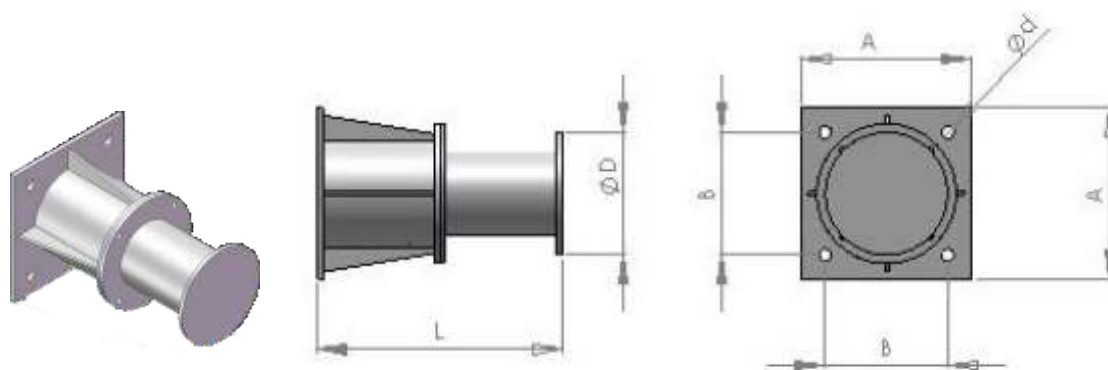

MODEL	STROKE IN MM	ENERGY CAPACITY NM/STROKE	ENERGY CAPACITY PER HOUR NM/HR	A	B	D	L	d2
SB-1204A	55	140	42000	150	120	100	185	13
SB-1204B	75	390	117000	200	160	125	285	17
SB-1204C	100	1700	510000	250	200	150	350	21
SB-1204D	125	2550	765000	300	240	175	445	25
SB-1204E	150	4100	1230000	350	290	200	575	25
SB-1204F	110	5000	1500000	370	250	250	540	25
SB-1204G	150	5000	1500000	350	250	250	500	25
SB-1220-A	170	7110	2133000	400	300	300	700	25
SB-1220-B	250	10400	3120000	400	300	300	940	25
SB-1220-C	170	7500	2250000	400	300	300	700	25
SB-1220-D	200	9400	2820000	400	300	300	770	25
SB-1220-E	200	8300	2490000	400	300	300	770	25
SB-1220-F	240	16000	4800000	500	300	300	1020	25
SB-1220-G	250	14000	4200000	400	300	300	985	26
SB-1220-H	250	12500	3750000	400	300	300	885	26
SB-1220-J	260	28000	8400000	500	400	300	1050	26
SB-1220-K	150	10700	3210000	400	300	300	423	26
SB-1220-L	200	8300	2490000	400	300	300	565	26
SB-1220-M	200	12500	3750000	400	300	300	585	26
SB-1220-N	150	14000	4200000	400	300	300	595	26
SB-1220-P	150	12500	3750000	400	300	300	500	26

SB

Industrial Shock Absorber



- Two locknuts inclusive
- Hydraulic Hardness Adjustable
- Spring Return
- Urethane Striker Cap
- Special Anticorrosive Finish
- Hardened and polished rod
- Special Viton Seals
- Adjustment axially at Bottom
- Nitrided wear parts for higher life
- Stainless steel model available on request



Hydraulic Feed Rate Controllers

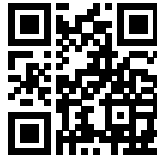

- Strokes available 25, 50, 75 and 100mm
- Used in Pneumatic Drilling
- Used largely for opposing the motion of Pneumatic Cylinder
- Smooth Movement
- Optional Pneumatic Reset
- Standard Model with Spring Return



Linear Motion Slides

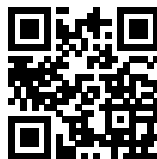

adoniTech has launched a new solution to the linear motion technology the Linear Motion Slides. The featured product is a adoniTech Linear Motion Slide without drive arrangement. Variants as per the application are manufactured. The linear guidance system is profiled Linear Motion guideways with Recirculating ball type LM blocks.

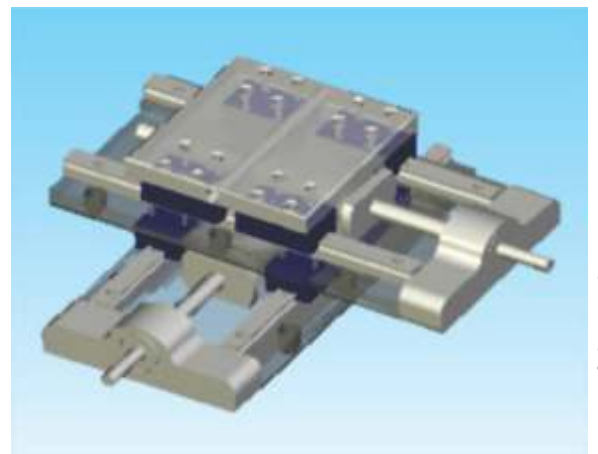

www.swiftdesigns.biz

ADONI TECH - Sharda 1st Floor, Jeevan Chaya Hsg. Soc., Opp. Civil Hospital, Satara - 415004. India. | **TEL** - (02162) - 232 169

WORKS - SLU/39, Addl. MIDC, Satara - 415 004. India. | **TELEFAX** - (02162) 240 695 | **CELL** - +91 989 085 2663

INTERNET - www.adonitech.co.in | **EMAIL** - sales@adonitech.co.in